



Australia New Zealand
Industrial Gas Association

ENVIRONMENTAL IMPACTS OF HYDROGEN PLANTS

AUSTRALIA NEW ZEALAND INDUSTRIAL GAS ASSOCIATION

PO Box 422
Flinders Lane 8009
+61 3 9611 5412
office@anziga.org
www.anziga.org

ENVIRONMENTAL IMPACTS OF HYDROGEN PLANTS Doc 122/18

Reproduced with permission from :



EUROPEAN INDUSTRIAL GASES ASSOCIATION AISBL

AVENUE DE L'ASTRONOMIE 30
B – 1210 BRUSSELS
+32 2 217 70 98
info@eiga.eu
www.eiga.eu

Guide to Use

The Australia New Zealand Industrial Gas Association (ANZIGA) is the industry association representing companies that produce and distribute industrial gases, including bulk and compressed gas for the industrial, medical, food, scientific and hospitality markets (referred as Industrial Gases) in Australia and New Zealand.

ANZIGA membership encompasses all the major producers and suppliers in both Australia and New Zealand.

ANZIGA has reproduced this publication with permission from the European Industrial Gases Association (EIGA). **This document has been provided as a useful guide** to our industry.

The publication, apart from this preface, is unaltered and represents current European practice based on EIGA representative members knowledge. The publication should be used with caution, as a reference only with attention paid to the disclaimer made by EIGA of its contents and this Preface including the disclaimer below. The information contained in the publication may not meet Australian Standards or Australian legislative requirements.

Users of this document in Australia or New Zealand should ensure they are in compliance with relevant local Acts, regulations, Codes of Practice and Australian/ New Zealand Standards.

The following referenced documents are an example of those that should not be relied upon and their use is cautioned, the local reciprocal legislation must be sought out and followed:

- EU Directives
- Pressure Equipment Directives
- Transportable Pressure Equipment Directives
- ATEX Directives
- ISO standards

Compliance with the relevant Australian and New Zealand requirements is essential. Users should consider:

- Work Health and Safety Legislation
- Occupational Health and Safety Legislation
- Dangerous goods Transport legislation
- National Transport Commission requirements
- Plant Regulations, design regulations requirements
- Australian Standards
- New Zealand Standards

Disclaimer

This publication contains information sourced by ANZIGA from a third party. The information is intended only as a guide of approaches adopted in Europe. While ANZIGA has taken care to ensure the publication has been reproduced accurately, you should not rely on the information as being suitable for your particular circumstances. The information is also not intended to replace any training required by the regulatory authorities or which may generally be desirable. Legislation and approved standards concerning the subject matter of this publication may apply. You should obtain appropriate legal or technical advice and you should also refer to the applicable legislation and any relevant approved standards to ensure compliance with your legal obligations.

ANZIGA has no control whatsoever on the use of any information or suggestions contained in this publication. To the extent permitted at law, ANZIGA in its own right and on behalf of its members expressly disclaims liability for all loss, including damage to or loss of property, personal injury, death and economic loss, that may arise as a result of negligence, or other tort, or breach of statutory or contractual obligation, on the part of ANZIGA or any of its members in the preparation, circulation and distribution of this publication.

Table of Contents

1	Introduction	0
2	Scope and purpose.....	0
2.1	Scope.....	0
2.2	Purpose.....	0
3	Definitions	0
3.1	Environmental aspect	0
3.2	Environmental Impact.....	0
4	Hydrogen production	0
4.1	General environmental aspects and impacts and links to other EIGA documents	0
4.2	Manufacture of hydrogen and the Industrial Emissions Directive (IED).....	1
4.3	Production methods.....	1
4.3.1	Electrolysis	1
4.3.2	Chemical processes	1
4.3.3	Steam reforming	1
4.3.4	Methanol cracking.....	2
4.3.5	Hydrogen purification	2
4.4	Carbon dioxide emissions for the different options	2
4.5	Environmental impact of a hydrogen production plant	2
4.5.1	Principal impacts	2
4.5.2	Compression	2
4.5.3	Desulphuriser	4
4.5.4	Reformer	4
4.5.5	High temperature shift.....	5
4.5.6	PSA Adsorbents	5
4.5.7	Maintenance.....	5
4.5.8	Storage.....	6
5	References.....	7
	Appendix 1: EIGA Document Links to ISO 14001 2015.....	8
	Appendix 2: Schematic of Hydrogen Production Plant.....	10
	10
	Appendix 3: Emissions or Waste – Hydrogen and Carbon Monoxide Plant.....	11

Amendments to 122/11

Section	Change
All	Editorial changes in line with current EIGA style manual
4.5.8.4	Section on Energy Management Added

NOTE Technical changes from the previous edition are underlined

1 Introduction

This publication details the environmental impacts of the production of hydrogen and gives guidelines on how to reduce this impact.

2 Scope and purpose

2.1 Scope

The publication concentrates on the environmental impacts of hydrogen production. It does not give specific advice on health and safety issues, which shall be taken into account before undertaking any activity. On these issues the relevant EIGA documents, and or national legislation should be consulted for advice.

2.2 Purpose

This publication is intended to serve as a general guide for hydrogen plant operations to assist in putting in place a formal environmental management system that can be certified by an accredited third-party verifier. It aims to provide a guide for operating managers for identifying and reducing the environmental impacts of these operations.

It also provides the basis for establishing the Best Available Techniques for the purposes of *Directive 2010/75/EU of the European Parliament and of the Council of 24 November 2010 on industrial emissions (integrated pollution prevention and control)* [1]¹. It is not intended as a detailed design guide for hydrogen plant, but can be used to identify the possible impacts. Best Available Techniques issues are also addressed in Doc 155 *Best Available Techniques for hydrogen production by steam methane reforming* [2] and Doc 183 *Best Available Techniques for the co-production of hydrogen, carbon monoxide and their mixtures by steam reforming* [3].

Hydrogen and carbon monoxide plants with hydrogen production >25 tonnes per day (TPD) require a greenhouse gases permit under Directive 2003/87/EC of the European Parliament and of the Council of 13 October 2003 establishing a scheme for greenhouse gas emission allowance trading within the Community and amending Council Directive 96/61/EC [4].

3 Definitions

3.1 Environmental aspect

These are elements of an organisation's activities, products or services that can interact with the environment. For example, use of energy or transportation of products.

3.2 Environmental Impact

Any change to the environment, whether adverse or beneficial, wholly or partially resulting from an organization's environmental aspects. (Source: ISO 14001:2015 *Environmental Management*) [5]. For example: the contamination of water with hazardous substances

4 Hydrogen production

4.1 General environmental aspects and impacts and links to other EIGA documents

This document covers the environmental impact of hydrogen plants which are summarised in Appendix 2.

There are several other EIGA publications that provide more details on general environmental issues, legislation for the gas industry and operational good environmental practices e.g. EIGA Doc. 88, *Good environmental management practices for the industrial gas industry (GEMPs)* [6]. A list of these documents and their links to the ISO 14001 environmental management systems standard [5] is

¹ References are shown by bracketed numbers and are listed in order of appearance in the reference section

provided in Appendix 1. Appendix 1 also shows which of these documents are relevant to hydrogen plant operations.

4.2 Manufacture of hydrogen and the Industrial Emissions Directive (IED)

This directive covers hydrogen production in Annex 1 Section 4.2 (a), Production of inorganic chemicals.

Hydrogen production is also covered in Section 1.2, Refining of mineral oil and gas, for those plants using steam methane reforming, due to the fact that this process has similar emissions to a combustion process.

EIGA Doc. 155 [2] and EIGA Doc, 183 [3] provide a more detailed summary of the applicability of the Best Available Techniques required under the IED directive.

4.3 Production methods

Hydrogen is the ninth most frequent element in the crust of the earth, so it is available as a natural resource in a bound form as water or hydrocarbons. Hydrogen can be produced either by electrolysis of water, or by a chemical process.

4.3.1 Electrolysis

In the electrolysis process water is split by electrical energy to obtain hydrogen plus oxygen. In this process hydrogen is gained at the cathode with a purity of almost 100%.

Depending on size, type and conditions of the plant, the energy requirement for the production of 1 Nm³ hydrogen by means of electrolysis is in the range of 4.2 to 4.6 kW and this corresponds to a primary energy requirement of approx. 1.3 Nm³ methane per 1 Nm³ hydrogen. This figure can be reduced to 1.1 if the oxygen obtained as a by-product finds use in another process.

4.3.2 Chemical processes

Hydrocarbons are split by steam at temperatures between 250 and 900 deg C in the presence of a catalyst. A 75% by vol. hydrogen rich synthesis gas is generated, with a purity of 99.999% by vol. after purification.

4.3.3 Steam reforming

The steam reforming process of natural gas (mainly methane) converts the hydrocarbon and steam in the presence of a nickel catalyst into a hydrogen-rich synthesis gas at a temperature between 800 and 900 deg C and a typical pressure of 15 to 20 bar. This stream is finally purified to obtain 99.999% by volume hydrogen. The classical steam reforming process requires 0.48 Nm³ methane per 1 Nm³ hydrogen.

The feed is mixed with a split stream of hydrogen and then preheated in the heat exchanger prior to passing through a sulphur removal stage. The feed is then mixed with superheated steam. Whilst passing through the catalyst in the reformer tubes, the mixture of water vapour and feed is converted into a "syngas" consisting of hydrogen, carbon monoxide, carbon dioxide, water and methane. The hot syngas passes through the heat exchanger in which the main part of the sensible heat is utilised, thus adjusting the temperature of the syngas for the subsequent carbon monoxide shift process. In the cooler following the carbon monoxide shift process, the syngas is cooled to ambient temperature, water vapour is simultaneously condensed and subsequently separated.

The syngas now passes through the molecular sieve pressure swing adsorption (PSA) purification unit where the hydrogen is purified to the required purity. Tail gas produced in the PSA purification unit and stored in the tail gas buffer tank is fed with fuel to a high velocity burner that heats the reformer. The hot flue gases of the reformer pass through the waste heat boiler prior to being used to superheat feed and steam and to preheat the feed in the heat exchangers.

A steam reformer can be used for the production of hydrogen, carbon monoxide or both, depending on its design. The emissions from the plant can differ and depend on the design, operating parameters and purpose. Nevertheless, most of the impacts described in section 4.5 of this document are relevant for plants producing carbon monoxide.

4.3.4 Methanol cracking

At significantly lower temperatures than in the steam reforming process, between 250 and 300 deg C, the methanol cracking process splits methanol and steam in the presence of a copper catalyst. For the production of hydrogen with a purity of 99.999% by vol., an equivalent quantity of 0.59 Nm³ methanol per 1 Nm³ hydrogen is required.

Other processes include the POX process (Partial Oxidation) and the CAR -process (Combined Autothermal Reformer). Both processes use oxygen as an additional feed.

4.3.5 Hydrogen purification

Hydrogen produced by electrolysis is contaminated by oxygen, which is removed by catalytic de-oxidation, and water vapour which is removed in a dryer. The catalytic reforming processes produce a syngas with approximately 75% by volume of hydrogen at elevated pressure. The purification process is based on Pressure Swing Adsorption (PSA), where the syngas is adsorbed on activated carbon and molecular sieves at elevated pressure. In this way hydrogen can be purified up to 99.999% vol.

4.4 Carbon dioxide emissions for the different options

Two considerations can be made:

- Steam reforming plants produce carbon dioxide emissions directly from the plant. In steam reforming plants, the elevated temperatures required to separate hydrogen from water and hydrocarbons are provided by burners, which release flue gas to atmosphere.
- Water electrolysis process is free of direct carbon dioxide emissions, but corresponding or indirect emissions are produced by the power generating facility producing electricity. These indirect emissions are related to the type of fuel used in the electricity generating plant.

Approximate carbon dioxide emissions generated per 1 Nm³ of hydrogen produced are as follows, considering the average energy mix of electricity production in the EU:

- | | |
|---------------------|--|
| • Electrolysis | 2.6 kg carbon dioxide per Nm ³ hydrogen |
| • Steam reforming | 0.8 kg carbon dioxide per Nm ³ hydrogen |
| • Methanol cracking | 1.2 kg carbon dioxide per Nm ³ hydrogen |

4.5 Environmental impact of a hydrogen production plant

This document considers the environmental impact of the most commonly used hydrogen production process, steam methane reforming.

4.5.1 Principal impacts

The principal impacts, either by amount or by potential consequences on the environment are:

- emissions to air from the reformer;
- use of catalysts and chemicals in the process;
- use of oil;
- historical use of PCB (polychlorinated biphenyl) or other equivalent substances on older sites;
- emissions of volatile organic compounds (VOC): chlorinated solvents (HCFC, CFC) during maintenance or accidentally from the chillers; and
- discharges of contaminated water.

4.5.2 Compression

The principle impacts from the compression process are as follows.

4.5.2.1 Use of natural gas

The main raw material is natural gas and gas usage is optimised by plant design and by operating the plant within its design limits.

4.5.2.2 Noise

Noise can be considered as an environmental nuisance and can often be reduced by applying simple techniques (silencer or screen for instance). Emission measures and measurement may be done periodically to make sure that all regulations are followed. See EIGA Doc. 85 *Noise Management for the Industrial Gases Industry* [7] for more details.

The main sources of external noise at a hydrogen production site are:

- compressors and other process equipment, and
- venting of tanks or trailers.

To reduce the noise at the hydrogen plant the following should be considered:

- When purchasing or designing machinery and equipment, the sound levels shall be considered. The additional cost of choosing equipment with a comparable low noise level is low at this stage. To reduce the noise emission afterwards is much more expensive. Also, the EU Machinery Directive (Directive 2006/42/EC of the European Parliament and of the Council of 17 May 2006 on machinery, and amending Directive 95/16/EC) [8] prescribes the basic safety and health requirements that are to be established including sound levels.
- Operate equipment to minimise noise generation.
- The plant lay-out should be established considering the possibility of minimising sound generation and the sound levels at the site boundary, especially adjacent to sensitive areas.

4.5.2.3 Oil

There are different points of potential contamination by oil:

- from the compressors due to leaks, vapour emission, cleaning;
- from hydraulic systems;
- from transformers; and
- from intermediate storage of waste-oil and refill-oil.

Improvement in design and maintenance of the compressors can reduce these waste sources. The recommendations for the control and disposal of oil are as follows:

- on no account should oil be allowed to enter the drainage system from normal operations. If some oil is mixed with water (cleaning or rain water for instance) separate the oil from the water before disposing of the water to the drainage system (see water treatment paragraph 4.5.2.4);
- install a bund (or pit) at each compressor, oil storage or transformer installation to collect the oil from leaks and purges;
- do not mix different types of oil waste, store them by type and label appropriately;
- return the collected waste-oil to the supplier or to a specialised company, for treatment or recycling; and
- prevent inhalation of oil vapours by operators. Generally, vapour emission is low due to cyclone and/or electrostatic demisters. In some cases, vapour emission can be avoided by cooling.

4.5.2.4 Water

Specific attention shall be given to the water discharge network, and associated liquid effluents.

For example:

- cleaning water (detergent, oil);
- cooling water and cooling tower blow-down;

- condensates;
- rain water;
- domestic water; and
- water treatment chemicals and sludges from cooling tower or oily water separator.

All the wastewater streams shall be clearly identified.

Condensed water from air is usually acidic and may also contain metals leaching from piping and solder.

Recycled cooling water usually contains chemical treatment products used as biocides and to control corrosion. These include chromates, phosphonates, polyacrylates, zinc, etc. Some of these chemicals are strictly regulated, because of their bio-toxicity. They may enter the drainage system when the cooling circuit is purged.

Cleaning water may contain solid particles and dust.

The recommendations are as follows:

- use water treatment chemicals that do not contain chromates or mercury, and
- use the minimum quantity of treatment chemicals necessary to achieve adequate system protection and to make sure that the quality of the discharge complies with local and national regulation limit values.

A water discharge permit from the authorities is normally needed to regulate such discharges and this permit may cover:

- pH of discharge, and
- concentration of chromate and chromite.

Hence water may need to be neutralised before discharge and discharges of chromate and solids and oil should be removed from water before discharging it into the sewage system. Decanting and filtration may be used to improve the water quality before discharge.

4.5.3 Desulphuriser

Before the process feed can be reformed, sulphur species contained in the natural gas shall be removed to prevent the poisoning of process catalysts; if there is no sulphur in the process gas this step is not required.

The hydrogen sulphide formed is then captured by an in-situ reaction with zinc oxide to form zinc sulphide.

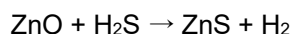

Spent catalyst may be removed from the tubes from the reactors by vacuuming under a nitrogen blanket. It shall then be either recycled by returning to the supplier or disposed of by certified waste disposal companies, and not regenerated onsite, as this is a specialist operation.

4.5.4 Reformer

The principle impacts from the reforming process are as follows.

4.5.4.1 Air emissions

At high temperature in the presence of nickel reforming catalyst, the mixed feed is converted into hydrogen and a mixture of carbon oxides in the following major reactions, which closely approach equilibrium:

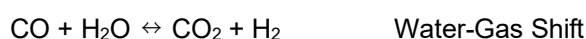
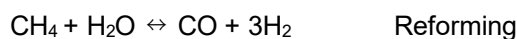

The process gas (syngas) effluent from the reformer tubes contains the desired hydrogen product plus by-product carbon monoxide and carbon dioxide, unreacted methane and water, and inerts from the feed.

Following the high temperature shift, which further converts the by-products into useful products, the resulting flue gas (mainly carbon dioxide with traces of nitrogen oxides, carbon monoxide, sulphur dioxide and water vapour) is typically vented to the atmosphere without the need for further treatment due to the relatively low levels of pollutants.

Low nitrous oxide burners are chosen as the best available technique for minimising air emissions and to optimise the conversion to hydrogen and minimise unwanted by products. In some cases, further treatment of the waste gases via scrubbing or selective catalytic reduction may be required.

4.5.4.2 Catalysts

The catalysts (nickel) contain biotoxic metals and shall be either recycled by returning to the supplier or disposed of by certified waste disposal companies. Catalysts are typically changed every 3-5 years.

4.5.5 High temperature shift

The water-gas shift reaction continues over the high temperature shift catalyst, and most of the carbon monoxide present is converted to carbon dioxide and additional hydrogen. Wastes include process condensate (section 4.5.2.4) and periodic change out of the catalyst (see 4.5.4.2).

4.5.6 PSA Adsorbents

The PSA contains solid granular alumina, molecular sieve, and activated carbon, which need periodic replacement and should be disposed of via certified contractors.

4.5.7 Maintenance

4.5.7.1 Regular maintenance

Regular maintenance is vital to keep the plant running as efficiently as possible, and to minimise environmental impacts. The change out of consumables and servicing of equipment do generate some wastes, which are detailed below.

4.5.7.2 Consumables

The storage of consumables should be reviewed to minimise the quantity of substances, spare parts, etc. used and stored at the site. It is recommended to:

- have safety data sheets available for all the hazardous chemical substances at the site and ensure that storage areas and vessels are properly labelled,
- store large volumes of oil, organic solvents or other hazardous substances with a secondary containment;
- have absorption material available to clean spill on the floor, and
- include environmental events such as major leakage of oil in the emergency plan.

4.5.7.3 Volatile organic compounds (VOC) from Solvents

Solvents may be used for cleaning These products are volatile compounds and without proper control part of them may disappear as emissions to the atmosphere.

Some halocarbons have ecological consequences, such as destroying the ozone layer. Some of them are banned from the market, according to the Montreal protocol and EU regulations, and the suppliers may propose less hazardous substitutes.

The recommendations are as follows:

- collect and label all waste and used liquid solvent and return to the supplier for recycling or reuse;

- consider recovering solvent and refrigerant for recycling; and
- avoid excess use of solvent, and review working practices and habits where solvent is used.

4.5.7.4 Polychlorinated biphenyls (PCB)

PCBs are toxic and carcinogenic substances used in electrical transformers, switchgear and capacitors. Their use has been phased out in accordance with prevailing legislation, see EIGA Doc 106, Environmental Issues Guide for more details.

If equipment with PCB (or equivalent substances) is used, it should be labelled accordingly. Disposal of this product and any material that is contaminated by PCB (for example rags, absorbent material and so on) should be controlled by national or local regulations.

PCB or PCB contaminated materials have to be collected into sealed suitable containers, labelled and then recovered and treated by certified waste disposal companies.

4.5.7.5 Batteries and electrical cells

Most batteries and electrical cells contain hazardous compounds. According to the kind of chemicals and composition, they shall be:

- returned to supplier for recycling, or
- disposed of by certified waste disposal companies.

4.5.7.6 Metal waste

Biotoxic metal wastes (for example mercury, cadmium, lead and their compounds) are strictly regulated and have to be disposed of by certified waste disposal companies.

Scrapped metals should be segregated into ferrous and non-ferrous and recycled.

4.5.7.7 Insulation material

Do not remove insulation material, unless strictly necessary, due to potential hazards and the fact that removed insulation is sometimes difficult to put back.

Recovered insulation material shall be returned to the supplier or disposed of by certified waste disposal companies.

Insulation material containing asbestos or refractory ceramic fibres (RCF) shall be identified. When removing this material, special precautions and control have to be taken according to hazard of the product and the local or national regulations, and specialist approved contractors are needed. Material shall be disposed of by a certified waste disposal company and handled in such a way to prevent release of asbestos or refractory ceramic fibres; this may include enclosing in a sealed bag, or wetting the material. See EIGA Doc207 Safe Operation and Maintenance of Furnaces Insulated with Refractory Ceramic Fibres (RCF) [9].

4.5.8 Storage

4.5.8.1 Waste storage

All waste which will be recovered, recycled or treated by a specialised company, or which will be disposed of at authorised facilities shall be stored and transported by authorised transporters in suitable containers clearly labelled to identify the composition of the waste. Liquid waste storage facilities should be bunded to a capacity capable of safely containing at least the contents of the largest single container.

Different kinds of waste shall not be mixed but shall be separated in different containers according to their type and the treatment they will receive.

The storage itself shall be organised in such a way that there is no risk of mixing the containers (separations in specific area, marking, records etc).

4.5.8.2 Underground storage tanks

These should be avoided on new facilities and more details can be found in EIGA Doc 106 *Environmental Issues Guide* [10].

4.5.8.3 Above ground storage tanks

Above ground storage tanks entail a risk of contamination of soil and water if the tank starts to leak, although the control of tank leakage is less complicated than for underground tanks. Even a dripping valve could easily contaminate several cubic meters of soil. Spill plates should be used. More details can be found in EIGA Doc 106 [10].

4.5.8.4 Energy Management

Hydrogen plants should take advantage of co-production synergies wherever technically and economically feasible. This would lead to integration into energy management systems of nearby sites. Available energy sources (refinery gas, steam, heat, power, etc.) from nearby sites can also be used and exported back so as to be integrated in facility operations.

An efficiency evaluation at the plant design stage should be used to identify these issues and input into the design process. The main techniques are optimised waste heat recovery to minimise fuel consumption, and integration into the energy system of the refinery or nearby site. In addition, energy efficiency can be improved by either optimising the conversion of the feed and/or the combustion efficiency.

Plant control and the maintenance system should be designed to ensure that energy is used as efficiently as possible, with the constraints of the safe and reliable operation of the plant and the design energy import and export requirements, see EIGA TB15/15 on Energy Efficiency Directive.

5 References

- [1] *Directive 2010/75/EU of the European Parliament and of the Council of 24 November 2010 on industrial emissions (integrated pollution prevention and control)*. OJ L 334, 17.12.2010
- [2] EIGA Doc 155 *Best Available Techniques for hydrogen production by steam methane reforming*. www.eiga.eu
- [3] EIGA Doc 183 *Best Available Techniques for the co-production of hydrogen, carbon monoxide and their mixtures by steam reforming*. www.eiga.eu
- [4] Directive 2003/87/EC of the European Parliament and of the Council of 13 October 2003 establishing a scheme for greenhouse gas emission allowance trading within the Community and amending Council Directive 96/61/EC. OJ L 275, 25.10.2003, pp. 32-46.
- [5] ISO 14001 *Environmental Management* www.iso.org
- [6] EIGA Doc. 88, *Good environmental management practices for the industrial gas industry (GEMPs)*. www.eiga.eu
- [7] EIGA Doc. 85, *Noise Management for the Industrial Gases Industry* www.eiga.eu
- [8] *Directive 2006/42/EC of the European Parliament and of the Council of 17 May 2006 on machinery, and amending Directive 95/16/EC (recast) (Text with EEA relevance)*. OJ L 157. 9.6.2006.
- [9] EIGA Doc.207 *Safe Operation and Maintenance of Furnaces Insulated with Refractory Ceramic Fibres (RCF)*. www.eiga.eu
- [10] EIGA Doc 106, *Environmental Issues Guide* www.eiga.eu

Appendix 1: EIGA Document Links to ISO 14001 2015

Doc No	Title of EIGA Document	ISO 14001:2015 SECTIONS	Clause
107	Guidelines on Environmental Management Systems ¹⁾	Context of the organization	4
		Understanding the organization and its context	4.1
		Understanding the needs and expectations of interested parties	4.2
		Determining the scope of the environmental management	4.3
		Environmental management system	4.4
		Leadership	5
		Leadership and commitment	5.1
		Policy	5.2
		Organization roles, responsibilities and authorities	5.3
		Planning	6
		Actions to address risks and opportunities	6.1
		General	6.1.1
106	Environmental Issues Guide ¹⁾	Environmental aspects	6.1.2
108	Environmental Legislation Applicable to Industrial Gases Operations within the EU ¹⁾	Legal requirements and voluntary obligations	6.1.3
		Environmental objectives and planning to achieve them	6.2
		Environmental objectives	6.2.1
		Environmental improvement programmes	6.2.2
		Support	7
		Resources	7.1
		Competence	7.2
		Awareness	7.3
		Communication	7.4
		General	7.4.1
		Internal communication	7.4.2
		External communication and reporting	7.4.3
		Documented information	7.5
		General	7.5.1
		Creating and updating	7.5.2
		Control of documented information	7.5.3
88	Good Environmental Management Practices for the Industrial Gas Industry ^{1 and 2)}	Operation	8
30	Disposal of Gases		
85	Noise Management for The Industrial Gases Industry ¹⁾		
109	Environmental Impacts of Acetylene Plants		

Doc No	Title of EIGA Document	ISO 14001:2015 SECTIONS	Clause
84	Calculation of Air Emissions from Acetylene Plants		
05	Guidelines for the Management of Waste Acetylene Cylinders		
166	Guidelines on Management of Gas Cylinders		
94	Environmental Impacts of Air Separation Units		
110	Environmental Impacts of Cylinder Filling Plants	Operational planning and control	8.1
117	Environmental Impacts of Customer Installations		
101	The Carbon Dioxide Industry and the Environment		
106	Environmental Issues Guide		
111	Environmental Impacts of Carbon Dioxide and Dry Ice Production ²⁾		
122	Environ. Impacts of Hydrogen Plants		
112	Environ. Impacts of Nitrous Oxide Plants		
113	Environmental Impacts of Transportation of Gases		
137	Environmental Aspects of Decommissioning		
		Value chain planning and control	8.2
		Emergency preparedness and response	8.3
		Performance evaluation	9
		Monitoring, measurement, analysis and evaluation	9.1
		General	9.1.1
		Evaluation of compliance	9.1.2
135	Environmental Auditing Guide ¹⁾	Internal audit	9.2
		Management review	9.3
		Improvement	10
		Nonconformity and corrective action	10.1
		Continual improvement	10.2
NOTES			
1	Specific document relevant to CO ₂ and dry ice.		
2	General document useful to CO ₂ and dry ice.		

What Documents are relevant to me?

For hydrogen plants, the relevant documents specific documents are highlighted in bold, and useful general document in italics.

Appendix 2: Schematic of Hydrogen Production Plant

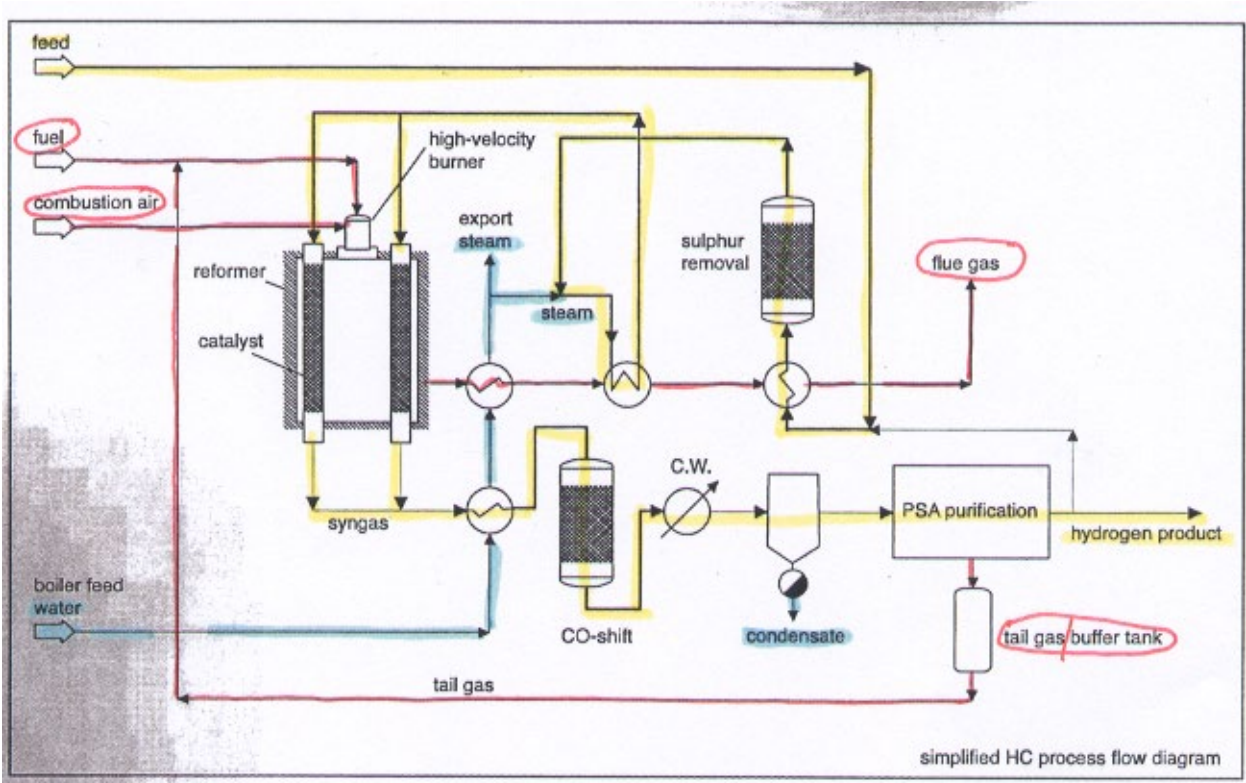

Appendix 3: Emissions or Waste – Hydrogen and Carbon Monoxide Plant

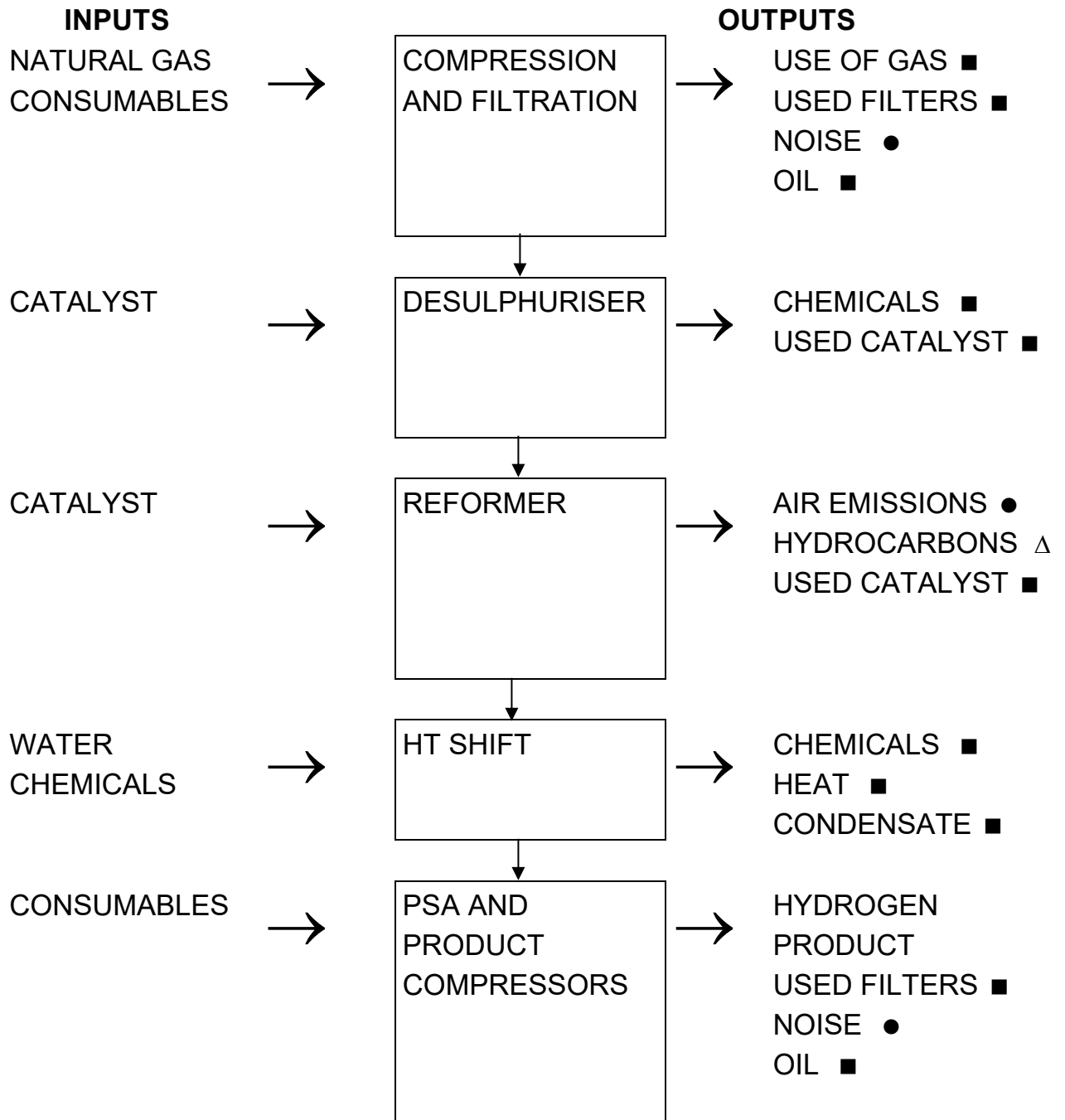

PERSISTENT ●
 PERIODIC △
 OCCASIONAL OR ACCIDENTAL ■